

Introduction to Acousto-Optics

Background

Acousto-Optic devices are used in laser equipment for electronic control of the intensity and position of the laser beam. In this note, we will explain the theory and application of acousto-optic modulators. Acousto-optic interaction occurs in all optical mediums when an acoustic wave and a laser beam are present in the medium. When an acoustic wave is launched into the optical medium, it generates a refractive index wave that behaves like a sinusoidal grating. An incident laser beam passing through this grating will diffract the laser beam into several orders. With appropriate design, the first order beam has the highest efficiency. Its angular position is linearly proportional to the acoustic frequency, so that the higher the frequency, the larger the diffracted angle.

$$\Theta = \frac{\lambda \cdot f_a}{V_a}$$

Where, λ , is the optical wavelength in air, f_a , is the acoustic frequency, and, V_a , is the acoustic velocity, and Θ , is the angle between the incident laser beam and the diffracted laser beam, with the acoustic wave direction propagating at the base of the triangle formed by the three vectors.

A diagram of the angular relationship between the acoustic wave and the laser beams is shown in Figure 1. The intensity of light diffracted (deflected) is proportional to the acoustic power (P_{ac}), the material figure of merit (M_2), geometric factors (L/H) and inversely proportional to the square of the wavelength.

This is seen in the following equation:

$$D.E. = \mathbf{h} = \sin^2 \left[\frac{\mathbf{P}}{\mathbf{I}} \left(\frac{M_2 \cdot P_{ac} \cdot L}{2 \cdot H} \right)^{1/2} \right]$$

With acousto-optics, both deflection as well as modulation of the amplitude of the beam are

possible. Also, in the acousto-optic interaction, the laser beam frequency is shifted by an amount equal to the acoustic frequency. This frequency shift can be used for heterodyne detection applications, where precise phase information is measured.

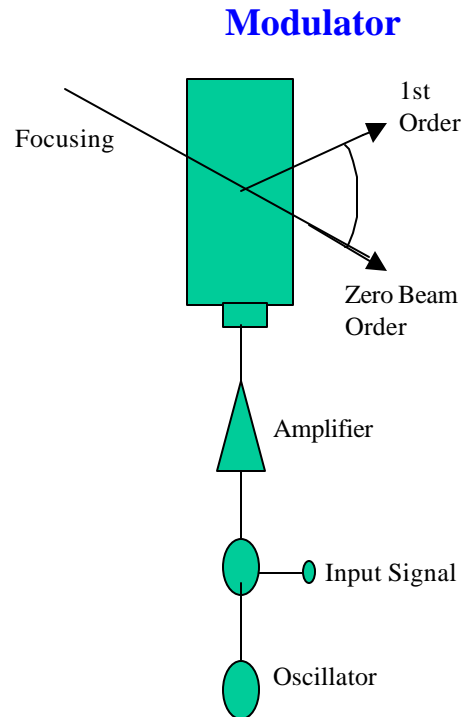



Acousto-Optic Material Selection

A variety of different acousto-Optic materials are used depending on the laser parameters such as laser wavelength (optical transmission range), polarization, and power density. Table 1 is a summary of the most common materials used for Brimrose's acousto-optic modulators. For the visible region and near infrared region the modulators are commonly made from gallium phosphide (Brimrose Pioneered), tellurium dioxide, indium phosphide (Brimrose pioneered), or fused quartz. At the infrared region, germanium is the only commercially available modulator material with relatively high figure of merit. Lithium niobate, indium phosphide, and gallium phosphide are used for high frequency (GHz) signal processing devices.

MATERIAL	OPTICAL RANGE (micron)	OPTICAL POLARIZATION	MAX CW LASER POWER (watt/mm ²)	REFRACTIVE INDEX	ACOUSTIC MODE	ACOUSTIC VELOCITY (km/sec)	FIGURE OF MERIT x10 ⁻¹⁵ m ² /w	MODULATOR SERIES
Chalcogenide Glass	1.0 - 2.2	Random	0.5	2.7	L	2.52	164	AMM-0-0
Flint Glass SF6	0.45 - 2.0	Random	0.7	1.8	L	3.51	8	FGM-0-0
Fused Quartz	0.2 - 4.5	Linear	> 100	1.46	L	5.96	1.56	FQM-0-0
Gallium Phosphide	0.59 - 10.0	Linear	5	3.3	L	6.3	44	GPM-0-0
Germanium	2.0 - 12.0	Linear	2.5	4.0	L	5.5	180	GEM-0-0
Indium Phosphide	1.0 - 1.6	Linear	5	3.3	L	5.1	80	IPM-0-0
Lithium Niobate	0.6 - 4.5	Linear	0.5	2.2	L	6.6	7	LNLM-0-0
Lithium Niobate	0.6 - 4.5	Linear	0.5	2.2	S	3.6	15	LNLM-0-0
Tellurium Oxide	0.4 - 5.0	Random	5	2.25	L	0.62	34	TEM-0-0
Tellurium Oxide	0.4 - 5.0	Circular	5	2.25	S	5.5	1000	TEM-0-0

Table 1. Acousto-optic material characteristics.

Acousto-Optic Device Construction

Once the acousto-optic material is selected, it is optically polished and a lithium niobate transducer is metal-pressure bonded to the modulator medium using an advanced technique. Brimrose's metal bonding provides a far superior acoustic coupling than epoxy bonding. We use only high quality metal bonds. The transducer is then lapped to the fundamental resonant frequency, such as 1 GHz.



Acousto-Optic Device Construction

Once the acousto-optic material is selected, it is optically polished and a lithium niobate transducer is metal-pressure bonded to the modulator medium using an advanced technique. Brimrose's metal bonding provides a far superior acoustic coupling than epoxy bonding. We use only high quality metal bonds. The transducer is then lapped to the fundamental resonant frequency, such as 1 GHz.

Anti-Reflection Optical Coating

Brimrose uses multi-layer dielectric broadband or "V" AR coatings for the A-O modulators. Typical losses are from a few percent for external cavity devices to 0.2 percent for intra-cavity devices.

Digital Modulation

For A-O modulators the principal performance parameter is the modulation speed which is primarily determined by the transit time, t . The transit time, t , and the rise time, t_r , are given by:

$$t = \frac{V}{d}$$

$$t_r = 0.85 \cdot t$$

To obtain a high modulation speed, t , should be as small as possible. In practice, the illuminating optical wavefront is usually brought to a focus within the interaction region of the A-O modulator. Divergence angle, $\Delta\theta$, of the acoustic wave should closely approximate the divergence angle, $\Delta\Phi$, of the optical wave to ensure that all the incident light is diffracted as shown in Figure 2. The acousto-optic modulator can be used to shutter the laser beam "on" and "off" by an external digital TTL signal.

The TTL signal allows for easy interface to a computer. To support the on-off signal, the rise time of the modulator system has to follow the digital waveform transition. The plots of rise time

vs. spot size for three common A-O modulator materials are given in Figure 3.

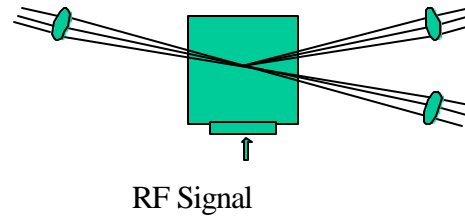
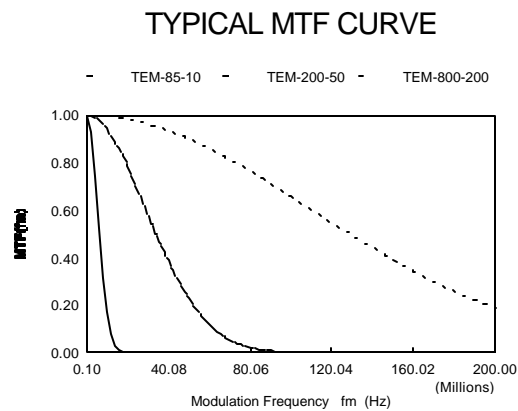

Figure 2. Focusing for A-O Modulator



Analog Modulation

The acousto-optic modulator has a nonlinear transfer function; therefore, care must be exercised when using it as an analog modulation system. For example gray level control, the best approach is to characterize the transfer function and apply the appropriate voltage levels into the 50 ohm impedance input drive port. For sinusoidal modulation, a bias is required to move the operating point to the linear region of the transfer function and focusing may be necessary to ensure that the rise time is adequate.



The modulation transfer function model is given by the following equation.

$$MIF = \exp \left[- \left(\frac{f_m}{1.2 \cdot f_0} \right)^2 \right]; f_o = \frac{0.35}{t_r}$$

Where, f_m is the modulating frequency. A typical MTF function is shown in Figure 4. The video bandwidth is defined by the frequency range, f_m , at which the MTF falls down to 0.5. The modulation contrast ratio at any, f_m , can be obtained from:

$$CR(f_m) = \frac{1 + MTF(f_m)}{1 - MTF(f_m)}$$

DC Contrast Ratio

The dynamic contrast ratio decreases as the modulation frequency increases and the modulator frequency responses degrades in performance.

The DC contrast ratio is defined as:

$$CR = \frac{I_{\max}}{I_{\min}}$$

Where I_{\max} = maximum laser intensity measured, and I_{\min} = maximum laser intensity measured for the first orier beam. In the DC case, the I_{\min} consists of contributions of the scattered light and of light modulation from leakage RF power driving the modulator. For optimum contrast ratio, I_{\max} must be optimized. DC contrast ratio is between 500 to 1000.



Acousto-Optic Driver Construction

The RF driver usually consists of an RF oscillator and amplitude modulator with an interface, which accepts, input modulation, and an RF amplifier which drives the AO modulator. The specifications in the catalog describe the performance of the modulator/driver systems in detail.

Glossary

AOBD....	Acousto-Optic Beam Deflector
D....	Optical Aperture (meters)
$\Delta\Phi$	Natural Divergence Of Collimated Laser Beam With Aperture Width D
λ	Optical Wavelength in Free Space (meters)
ΔF_a	Total Bandwidth (MHz)
ΔT	Aperture Time (seconds)
p....	Truncation Factor of Laser Beam
W....	Focused Beam Diameter at 1/e Intensity Points
a....	is a predetermined beam parameter
FL....	Lens Focal Length (meters)
Df_a/dt	FM rate
M_2	Acoustic Figure Of Merit
P_{ac}	Acoustic Power (watts)
t....	Modulated Laser Beam Rise Time (seconds)
DIA....	Laser Beam Diameter
MTF....	Modulation Transfer Function
f_m	Modulation Frequency
f_o	Characteristic Frequency
I_{max}	Maximum Intensity
I_{min}	Minimum Intensity
CR....	Contrast Ratio
V Coat....	Narrow Band AR coating
θ_b	Bragg Angle
θ	$2\theta_b =$ Deflection Angle
f_a	Acoustic Frequency (MHz)
η	Diffraction Efficiency Of Modulator
L....	Interaction Length
H....	Transducer Height



AOTF SPECTROSCOPY

A POWERFUL NEW TOOL IN NEAR INFRARED SPECTROSCOPY

In this application note we discuss how the special properties of an acousto-optic tunable filter (AOTF) can be used to eliminate many of the practical problems associated with industrial or process control near-infrared spectroscopy.

INTRODUCTION

Near-infrared spectroscopy is a technique that has gained widespread acceptance in recent years as a powerful diagnostic tool, particularly for quality assurance and process control purposes. It has already been proven in such diverse applications as quantitative analysis of pharmaceuticals, cosmetics and gasoline (including octane number), manufacturing and quality assurance for soft drinks and beer, confirming the ripeness of fruit, and spectroscopic imaging of biological and medical materials.

To successfully deploy NIR spectroscopy in most real applications requires recording data at a number of different wavelengths. Some type of monochromator, or wavelength selection device, is therefore an essential part of any NIR spectrometer. Unfortunately, traditional monochromators (using diffraction gratings) require careful handling and frequent calibration. In addition, their performance is easily degraded in an industrial environment, making them less than perfect for use in an on-line process control application. It also takes a relatively long time to scan such a device between different wavelengths reproducibly.

The acousto-optic tunable filter (AOTF) on the other hand has almost ideal properties for performing NIR spectroscopy. It is an all solid-state tunable filter with no moving parts and is therefore immune to orientation changes or even severe mechanical shock and vibrations.

This comparatively new technology is capable of excellent resolution and can be easily incorporated in a sealed system using fiber optics for measuring remote samples or for use in extremely hostile conditions. Not only does it have no moving parts to calibrate, but the AOTF is also a high speed programmable device capable of randomly accessing thousands of precise wavelengths in less than a second, making it an excellent tool for NIR

spectroscopy. Consequently, AOTF based spectrometers can increase the power of NIR spectroscopy to such a degree that they are expected to literally revolutionize the field, opening up a host of new applications, including spectroscopic imaging*, as well as improving the capabilities of existing ones.

* See for example, P.J. Treado, I.W. Levin and E.N. Lewis, Applied Spectroscopy, 46, 4 1992

NEAR INFRARED SPECTROSCOPY

The near-infrared, or NIR, spectral region is loosely defined as the wavelength region from 700 nm out to 2-3 microns. Many molecules have characteristic vibrational overtones ($\Delta\delta > 1$) that give rise to absorption bands in this part of the electromagnetic spectrum. Consequently, NIR absorption spectra can be used to identify molecular species and evaluate concentrations or mole fractions in complex mixtures as diverse as soft drinks and formulated cosmetics.

Vibrational Band Overlap

The strongest NIR absorption bands are usually associated with the first and second overtones (or combination bands) of high frequency stretching vibrations. The wavelengths at which these vibrations occur for a particular chemical is a function of its structure and composition: the first overtone of O-H stretching vibrations are usually in the 1350 - 1450nm region, whereas the second overtone of a C-H stretching vibration can vary from approximately 1070 nm in a vinyl group to 2500 nm in some aliphatic molecules.

Unfortunately, interpreting near-infrared (NIR) spectra to derive the composition or concentrations of constituents is fairly complex in comparison to many other spectroscopic techniques. Concentrations or other important parameters cannot be measured solely by the absorption or reflectivity value at a single NIR wavelength. The reasons for this difficulty are severe band congestion and overlap (see Figure 1). Since NIR absorption bands are broad, and because there may be several vibrational bands in the same spectral region (even for a single molecular species), significant problems are usually encountered during analysis.

For example, a sugar molecule may have several, slightly displaced but overlapping C-H stretches not to mention a host of weaker combination bands, making it difficult or impossible to resolve and identify individual vibrational bands. This problem may be additionally compounded by



unpredictable light scattering and refractive index changes in the samples, producing sloping or variable baselines. Obviously this situation is further complicated in analyzing the NIR spectra of mixtures of two or more compounds. Such spectra rarely have any zero absorption or baseline regions making even simple evaluations of absolute intensities difficult (see Figure 1). For example, the absorption at a given wavelength may contain contributions from several vibrations within more than one molecular species or substance. Single point analysis of such spectra is therefore not optimal for quantitative analysis.

Spectral Analysis

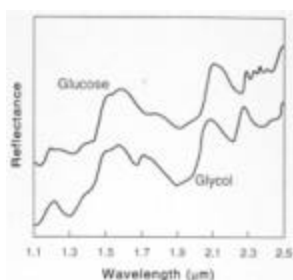

Figure 1. The NIR spectra of two common organic materials, glucose and glycole.

The key to interpreting NIR spectra is on-line data processing and chemometrics, which has become possible with the advent of spectroscopic systems with intelligence in the form of dedicated, or in some cases, built-in microprocessors or PC's.

Typically, the analysis would proceed in up to four distinct phases: data collection, data processing, and finally calibration and prediction (chemometrics). The data collection phase entails choosing the appropriate experimental/ instrumental conditions under which to collect the data. This may involve determining the optimal wavelength range, the amount of signal - averaging to perform, or perhaps the choice between transmittance, reflectance, or transreflectance modes. The data processing or preprocessing phase refers to treating the data with a variety of digital techniques which have the affect of redistributing the information content of the spectrum to a form more tractable to the subsequent chemometric analysis. These include signal averaging, spectral subtraction or normalization, instrument response correction or the calculation of derivatives, and even more elaborate methods such as, spectral deconvolutions or maximum entropy calculations in some cases. Chemometrics refers to a variety of mathematical methods, including multivariate statistics, for

analyzing or improving the analysis of chemical data. These methods allow, for example, the empirical interpretation of NIR spectra to yield highly accurate and reliable data on composition, mole fraction and even such complex parameters as the octane number of gasoline. There are a wide variety of multivariate statistical approaches useful in NIR spectral analysis: Classical least squares (CLS), inverse least squares (ILS), partial least squares (PLS), and principal components regression (PCR).

The basic principles are the same for each method. The spectrometer's CPU records and stores spectra from a range of calibrated test samples. The software then tries to fit expressions that correlate spectral intensities to the known concentrations or other parameters of interest - within acceptable error limits determined by the quality of the data. These expressions may involve a few specific wavelengths from a spectrum or indeed the whole spectrum, depending on the analytical method employed. Once the instrument has derived these expressions it is able to simultaneously analyze and perform concentration predictions on unknown samples containing one or more components. As an example, Figure 2 shows the correlation between actual motor octane number and that predicted by NIR spectroscopy and multivariate spectral analysis for various blends of gasoline.

Limitations of Existing Technology

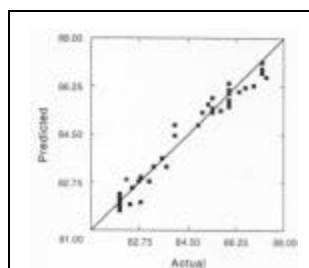

Figure 2. Correlatio of actual motor octane number for various gasolines. Prediction based on multivariate correlation analysis from J.J. Kelly et al., *Anal. Chem.* 1989, 61, 31.

Whatever type of monochromator or wavelength filtering device is employed in a NIR spectrometer, it is desirable that it be programmable, with fast and accurate random access. For industrial applications the spectrometer must also be rugged without the need for frequent maintenance or recalibration. Several different technologies have been employed in NIR spectrometers but each has serious limitations, particularly in an on-line industrial situation. The scanning diffraction grating spectrometer is a well-proven tool in many types of



spectroscopy. However, it needs to be frequently recalibrated, is susceptible to mishandling and damage in hostile environments, and takes a finite time to scan between wavelengths. The newer grating spectrometers using a fixed grating and detector array are much faster and better suited to the industrial environment, needing less maintenance and/or recalibration. However, the selected wavelength is still a function of a precise geometrical arrangement between the grating and detector. Vibration or mishandling can thus cause "blurring" of the image on the array, which translates into reduced performance. Another limitation of this type of instrument is that they can be used in only one of two modes, to record widespread spectral data at low resolution, or a limited spectral region at higher resolution.

Bandpass Filters simply do not offer the flexibility for most real world applications. A separate filter is needed for each wavelength data point. Fourier Transform (FT) spectrometers are available for the NIR spectral region and are capable of excellent resolution and sensitivity. Unfortunately since their operation involves precision translation of mirrors, their performance is also very sensitive to environment - vibrations and dust. In addition, they are relatively slow since they can only collect and compute spectral data over the entire combined bandpass of the instrument. Clearly, none of these technologies offers the required combination of speed, ruggedness, flexibility, reliability, and hands-off operation required in the vast majority of industrial applications, hence the interest in alternative technologies such as the AOTF.

WHAT IS AN AOTF?

Brief Description

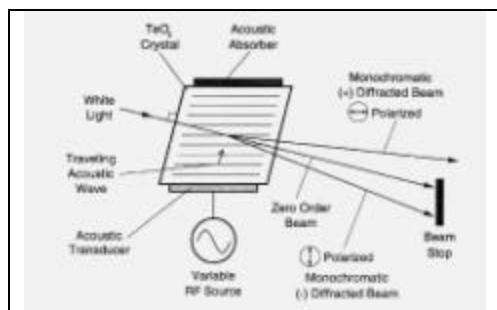

Figure 3. Schematic representation of a non-collinear AOTF.

An AOTF acts as an electronically tunable spectral bandpass filter. It is a solid state electro-optical device with no moving parts. It consists of a crystal in which acoustic

(vibrational) waves, at radio frequencies (RF) are used to separate a single wavelength of light from a broadband or multi-color source. The wavelength of light selected is a function of the frequency of the RF applied to the crystal. Thus, by varying the frequency of the RF, the wavelength of the separated or filtered light can be varied. This wavelength is independent of device geometry.

Technical Details

The most common types of AOTF which operate in the NIR region use a crystal of Tellurium Dioxide (TeO₂) in a so-called non-collinear configuration - the acoustic and optical waves propagate at quite different angles through the crystal. Figure 3 is a schematic representation of a TeO₂ AOTF. A transducer is bonded to one side of the TeO₂ crystal. This transducer emits vibrations (acoustic waves) when RF is applied to it. The frequency of the vibrations equals the frequency of the applied RF. As these acoustic waves pass through the TeO₂, they cause the crystal lattice to be alternately compressed and relaxed. The resultant refractive index variations act like a transmission diffraction grating or Bragg diffracter. Unlike a classical diffraction grating, however, the AOTF only diffracts one specific wavelength of light, so that it acts more like a filter than a diffraction grating. This is a result of the fact that the diffraction takes place over an extended volume, not just at a surface or plane, and that the diffraction pattern is moving in real time. The wavelength of light that is diffracted is determined by the "phase matching" condition as described:

$$I = \Delta n a \frac{v_a}{f_a}$$

where Δn is the birefringence of the TeO₂ crystal, δ_a and f_a are the velocity and frequency of the acoustic wave, and a is a complex parameter depending on the design of the AOTF. The wavelength of the light that is selected by this diffraction can therefore be varied simply by changing the frequency of the applied RF. As indicated in the figure, the diffracted light intensity is directed into two first order beams, termed the (+) and (-) beams. These beams are orthogonally polarized, which is utilized in certain applications. To use the AOTF as a tunable filter, a beam stop is used to block the undiffracted, broadband light and the (+) and/or (-) monochromatic light is directed to the experiment. The angle between the beams is a function of device design, but is typically a few degrees. The bandwidth of the selected light depends on the device and the



wavelength of operation, and can be as narrow as 1nm FWHM. Transmission efficiencies are high (up to 98%), with the intensity divided between the (+) and (-) beams. Another useful and unique feature of the AOTF is its ability to precisely and rapidly adjust the intensity of the diffracted (filtered) light by varying the RF power.

BENEFITS OF AOTF'S IN NIR SPECTROSCOPY

Since the AOTF acts as a tunable filter, it can act as the monochromator at the heart of a NIR spectrometer. In the following notes we discuss how the various features of an AOTF benefit NIR spectroscopic applications. These benefits make the AOTF more than just another technology for consideration, but unquestionably the ideal tool for NIR spectroscopy.

Repeatability/Calibration

The AOTF is an all solid state device with no moving parts, and the transmitted wavelength is independent of device geometry. In fact, the transmitted wavelength is determined only by the frequency of the applied RF, which can be generated with digital precision. This means that once an AOTF or AOTF spectrometer is factory calibrated, it will not need to be recalibrated.

Since NIR applications usually require measurements at multiple wavelengths, short and long term wavelength repeatability are highly advantageous. As an example, a typical TeO₂ AOTF has a guaranteed wavelength repeatability error of less than ± 0.05 nm.

Wavelength Purity

In NIR spectroscopic measurements, out of band transmission must be kept to a minimum, preferably zero. Out of band transmission is defined as the light transmitted at wavelengths other than the theoretical narrow band defined by the filtering device, in this case the AOTF. Clearly, out of band transmissions could cause severe problems in NIR spectroscopy making it difficult if not impossible to derive meaningful answers from the corrupted experimental data. Fortunately, the AOTF excels in this area too, with out of band transmissions as low as 10^{-5} for some devices (see figure 4).

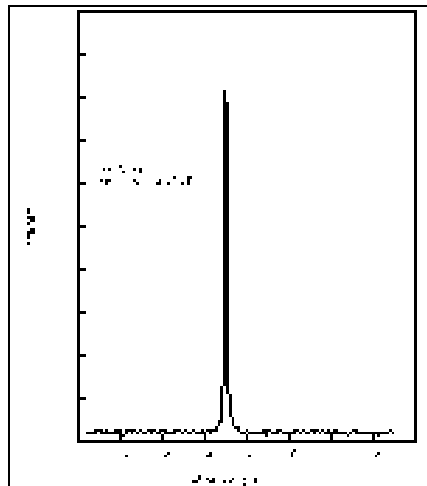

Figure 4. Plot of output spectrum of a Brimrose model TEAF-8-1.8S AOTF tuned to 1450nm. Note absence of out band transmissions.

Speed/Random Access

When the frequency of the rf is changed, the rate limiting factor in changing the wavelength is the time it takes for the changed RF to fill the AOTF crystal - typically 20 microseconds. This means that entire spectra can be scanned at very high speed, or discrete wavelengths may be accessed at rates of 10 KHz or greater, even when separated by hundreds of nanometers.

Computer Control/Integration

One of the most useful features of the AOTF is its high degree of controllability or programmability. In commercial AOTF's, the RF generator is interfaced directly to a microprocessor or computer. This enables an AOTF based spectrometer to be programmed to scan or access different wavelengths very rapidly, and even to change the output intensity at those wavelengths. In use, therefore, it is easily integrated into almost any computer controlled test or experiment.

Closed Loop Process Control

Computer control and/or on-board intelligence makes an AOTF spectrometer an ideal tool for closed loop process control. For example, an instrument of this type could reliably and rapidly measure the aspartane concentration in soda and, as a result, control the blending process in real-time.

Rugged Device/No Moving Parts



AOTF's are both compact and rugged. Clearly a device with no moving parts is much more insensitive to damage in industrial applications. Just as important, short of actually breaking the device, vibrations and shocks will not affect the wavelength calibration.

Closed System/Fiber Coupling

Other hazards presented by the industrial environment may include dust and corrosive vapors. The AOTF is easily incorporated into a bidirectional (bifurcated) fiber system as shown in Figure 5. In such a setup, the fiber is sealed directly to both the AOTF and detector to make a completely air-tight closed system. This allows remote sensing and also protects all the optical and electro-optical components from damage by dust or chemicals.

Efficiency/Sensitivity

The AOTF is a high efficiency device with transmission at the selected wavelength as high as 98%. Furthermore, the output of the AOTF is circular, collimated beam, which is ideally suited for coupling to a fiber, unlike the exit slit of a monochromator. High efficiency translates directly into higher sensitivity and therefore faster data acquisition.

Hands-Off Device

Once the AOTF or AOTF based spectrometer has been programmed to record a particular data set to compute a quality parameter or control a process, it requires no further attention. It can be programmed by an engineer or technician and then be operated in a hands-off mode or by an unskilled worker.

Use with Lock-in Amplifiers

Both the wavelength and intensity of the selected light are controlled electronically and can be rapidly modulated. This makes the AOTF ideal for use with a lock-in (phase sensitive) amplifier.

PRACTICAL AOTF SPECTROMETERS

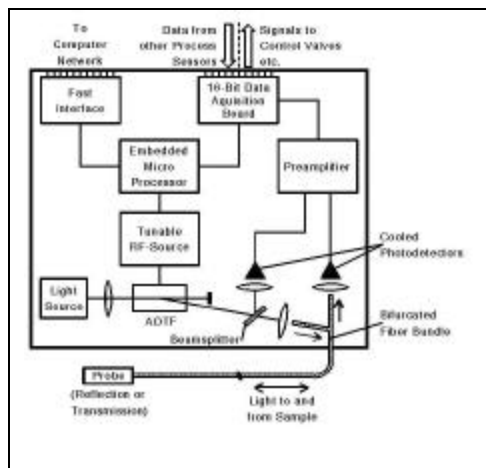

Figure 5. Schematic showing elements of a typical AOTF spectrometer (Brimrose Luminar)

Applying AOTF technology to NIR spectroscopic applications is analogous to many other areas of applied technology; some applications require custom instrumentation whereas others can be served perfectly well by standard instruments. BRIMROSE has over eight years of experience with AOTF technology, and now offers standard and custom self-contained spectrometers (visible and NIR) based on their own AOTF devices, as well as stand-alone AOTF's which can be readily used to construct custom spectrometers. The basic elements of an AOTF spectrometer are shown in Figure 5, a schematic representation of the Brimrose Luminar 2000 AOTF. This particular spectrometer was designed primarily for closed loop industrial process control, including fiber coupling for remote operation. However, it is a versatile instrument that can also function as a powerful laboratory tool.

In this spectrometer, the output of a white light source (quartz halogen lamp) is collimated and directed into a TeO₂ AOTF. The monochromatic output beam from the AOTF is coupled into a bifurcated fiber bundle. The fiber exits the spectrometer and terminates in a probe designed for reflectivity or finite path absorption measurements. Light from the sample passes back along the fiber where it is focused on to a photodetector. The signal intensity at each wavelength is digitized by a high speed 16-bit A/D converter before being stored and/or analyzed by the CPU. Having an internal or dedicated CPU is extremely important for both



industrial and laboratory applications, because analysis of NIR spectra always requires some degree of numerical computation. For process control applications, an embedded computer with appropriate software lends itself well to closed loop operation since the computer can be programmed not only to measure a process but to also control it by responding to the measured constituents. These responses can take the form of numerous kinds of digital or analog I/O to control flow valves, trip alarms or data transfer over a network to a central computer for storage or integration into a large scale process.

Figure 6 shows a transmission spectra of several alcoholic beverages recorded using this instrument. Notice the increased intensity of the methyl and methylene bands at approximately 1700 nm as the alcohol content increases.

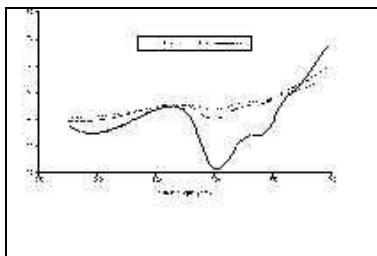

Figure 1. Transmission spectra of three beverages obtained with the Brimrose Luminar 2000 Spectrometer which shows the increase in absorption at around 1700 nm as the alcohol content increases.

fulfill its promise as an important on-line diagnostic tool. In fact, although systems using other technologies have been successfully deployed, AOTF technology is unique in its ability to satisfy all the criteria for hands-off NIR spectroscopy in the industrial environment.

CONCLUSION

NIR spectroscopy can be a powerful diagnostic in a wide variety of on-line or laboratory applications. However, to derive accurate compositional or quality parameters requires that data be recorded at multiple wavelengths in real time. A spectrometer must be able to repeatedly tune to these precise wavelengths reliably over long periods of time.

For industrial use it is also necessary that the spectrometer be rugged, flexible, and simple to operate. In addition, it is highly desirable that the instrument be compact and high speed in operation. Problems in meeting these requirements with "classical" spectroscopic technologies, for example grating spectrometers, have certainly delayed the wide spread deployment of NIR spectroscopy in industrial and commercial applications. With the advent of rugged, compact spectrometers based on AOTF technology, NIR spectroscopy is now set to

Brimrose Corporation of America
19 Loveton Circle
Baltimore, MD 21152-9201 USA
Phone: +1 410 472-7070
Fax: +1 410 472-7960
E-Mail: offices@brimrose.com
Web: <http://www.brimrose.com>



If you require further information on the topics discussed in this application note, or any other aspects of AOTF technology, contact our applications Engineers. They will be happy to answer your questions and support you with data and literature on specific **BRIMROSE** products