



## High Resoluton UV-VIS-IR Modulator (0.38 to 1.6 $\mu$ m)

**Models TEM-85-2, TEM-85-10, TEM-110-25, TEM-200-50, TEM-400-100, & TEM-800-200**

	<b>TEM-85-2</b>	<b>TEM-85-10</b>	<b>TEM-110-25</b>
Data Performed @	500 nm	500 nm	633 nm
Optical Power Density	5 Watts/mm <sup>2</sup>	5 Watts/mm <sup>2</sup>	5 Watts/mm <sup>2</sup>
Center Frequency	85 MHz	85 MHz	110 MHz
Active Aperture	2.0 mm	1.0 mm	0.3 mm
Beam Diameter Inside Crystal	1.4 mm	0.3 mm	0.1 mm
Rise Time	280 ns	55 ns	22 ns
Digital Modulation Bandwidth	2 MHz	10 MHz	25 MHz
Analog Video Bandwidth	1.3 MHz	6.3 MHz	16 MHz
Optical Transmission	> 95 %	> 95 %	> 95 %
Diffraction Efficiency	80 %	75 %	70 %
Wave Front Distortion	$\lambda/10$	$\lambda/10$	$\lambda/10$
Bragg Angle (mrad)	5	5	8.5
Separation Angle	10	10	17
Acoustic Velocity	4.2 E+3 m/sec	4.2 E+3 m/sec	4.2 E+3 m/sec
Maximum RF Power	1 W	1 W	0.5-1 W
V.S.W.R.	2:1	2:1	2:1
Input Impedance	50 ohms	50 ohms	50 ohms
Optical Polarization	Linear, perpendicular to sound direction →		
Case Type	# 30	# 30	# 200

## High Resolution IR Modulators (1 to 2.5 $\mu$ m)

**Models AMM-27-2, AMM-80-4, AMM-100-8, & AMM-100-13**

	<b>AMM-27-2</b>	<b>AMM-80-4</b>	<b>AMM-100-8</b>	<b>AMM-100-13</b>
Data Performed @	1550 nm	1550 nm	1550 nm	1550 nm
Optical Power Density	$\leq 3$ W/mm <sup>2</sup>	$\leq 3$ W/mm <sup>2</sup>	$\leq 3$ W/mm <sup>2</sup>	$\leq 3$ W/mm <sup>2</sup>
Center Frequency	27 MHz	80 MHz	100 MHz	100 MHz
Active Aperture	1 mm	1 mm	0.3 mm	0.3 mm
Beam Diameter Inside Crystal	0.8 mm	0.4 mm	0.2 mm	0.13 mm
Rise Time	300 ns	160 ns	68 ns	43 ns
Digital Modulation Bandwidth	1.8 MHz	4 MHz	8 MHz	13 MHz
Analog Video Bandwidth	1 MHz	2.2 MHz	5 MHz	8 MHz
Optical Transmission	> 95 %	> 95%	> 95%	> 95%
Diffraction Efficiency	> 75 %	> 70 %	> 60 %	> 55 %
Wave Front Distortion	$\lambda/10$	$\lambda/10$	$\lambda/10$	$\lambda/10$
Bragg Angle	8 mrad	24 mrad	31 mrad	31 mrad
Separation Angle	16 mrad	49 mrad	62 mrad	62 mrad
Acoustic Velocity	2.52E+3 m/sec →		2.52E+3 m/sec →	
Maximum RF Power	1 W	1 W	1 W	1 W
Input Impedance	50 ohms	50 ohms	50 ohms	50 ohms
V.S.W.R.	2:1	2:1	2:1	2:1
Optical Polarization	Any	Any	Any	Any
Case Type	# 200	# 200	# 200	# 200



## UV-VIS-IR Modulators *(0.2 to 1.3 μm)*

### Models FQM-80-2, FQM-80-20, & FQM-200-40

	<b>FQM-80-2</b>	<b>FQM-80-20</b>	<b>FQM-200-40</b>
Data Performed @	500 nm	500 nm	500 nm
Optical Power Density	100 Watts/mm <sup>2</sup>	100 Watts/mm <sup>2</sup>	100 Watts/mm <sup>2</sup>
Center Frequency	80 MHz	80 MHz	200 MHz
Active Aperture	1.6 mm	1 mm	0.3 mm
Beam Diameter Inside Crystal	1.4 mm	0.2 mm	0.1 mm
Rise Time	195 ns	30 ns	14 ns
Digital Modulation Bandwidth	2.8 MHz	18 MHz	40 MHz
Analog Video Bandwidth	1.8 MHz	11.7 MHz	25 MHz
Optical Transmission	> 98 %	> 98 %	> 98 %
Diffraction Efficiency	70 %	70 %	45-60 %
Wave Front Distortion	λ/10	λ/10	λ/10
Bragg Angle (mrad)	3.5 mrad	3.5 mrad	8.5 mrad
Separation Angle	7 mrad	7 mrad	17 mrad
Acoustic Velocity	5.96 E+3 m/sec	5.96 E+3 m/sec	5.96 E+3 m/sec
Maximum RF Power	5 W	3.5 W	3.5 W
Input Impedance	50 ohms	50 ohms	50 ohms
V.S.W.R	2:1	2:1	2:1
Optical Polarization.	Linear	Linear	Linear
Case Type	# 35	# 35	# 130

## IR Modulators *(2.0 to 11.0 μm)*

### Models GEM-40-1, GEM-40-4, & GEM-60-10

	<b>GEM-40-1</b>	<b>GEM-40-4</b>	<b>GEM-60-10</b>
Data Performed @	10.6 μm	10.6 μm	3.3 μm
Optical Power Density	5 Watts/ mm <sup>2</sup> (100 Watts max) →		
Center Frequency	40 MHz	40 MHz	60 MHz
Active Aperture	5.0 mm	1.5 mm	1.0 mm
Beam Diameter Inside Crystal	3.3 mm	0.8 mm	0.3 mm
Rise Time	510 ns	125 ns	50 ns
Digital Modulation Bandwidth	1 MHz	5 MHz	10 MHz
Analog Video Bandwidth	0.68 MHz	2.7 MHz	6.8 MHz
Optical Transmission	> 85 %	> 85 %	> 85 %
Diffraction Efficiency	35 %	70 %	75 %
Wave Front Distortion	λ/10	λ/10	λ/10
Bragg Angle (mrad)	39 mrad	39 mrad	18 mrad
Separation Angle	78 mrad	78 mrad	36 mrad
Acoustic Velocity	5.5 E+3 m/sec	5.5 E+3 m/sec	5.5 E+3 m/sec
Maximum RF Power	20-30 W	25 W	8 W
Input Impedance	50 ohms	50 ohms	50 ohms
V.S.W.R.	2:1	2:1	2:1
Optical Polarization	Linear	Linear	Linear
Case Type	# 90	# 90	# 35



## High Bandwidth VIS-IR Modulators (.6-1.6 μm)

### Models GPM-200-50, GPM-400-100, GPM-800-200, & GPM-1600-400

	<b>GPM-200-50</b>	<b>GPM-400-100</b>	<b>GPM-800-200</b>	<b>GPM-1600-400</b>
Data Performed @	800 nm	800 nm	800 nm	800 nm
Optical Power Density	up to 5 Watts/mm <sup>2</sup> →		up to 5 Watts/mm <sup>2</sup> →	
Center Frequency	200 MHz	400 MHz	800 MHz	1600 MHz
Active Aperture	0.3 mm	0.1 mm	0.05 mm	0.025 mm
Beam Diameter Inside Crystal	0.08 mm	0.04 mm	0.02 mm	0.01 mm
Rise Time	11 ns	5.1 ns	2.6 ns	1.4 ns
Digital Modulation Bandwidth	50 MHz	108 MHz	217 MHz	400 MHz
Analog Video Bandwidth	32 MHz	68 MHz	137 MHz	250 MHz
Optical Transmission	> 90 %	> 90 %	> 90 %	> 90 %
Diffraction Efficiency @ 800 nm	> 60 %	> 50 %	> 30 %	> 15 %
Diffraction Efficiency @ 633 nm	> 75 %	> 65 %	> 40 %	> 25 %
Wave Front Distortion	λ/10	λ/10	λ/10	λ/10
Bragg Angle (mrad)	13 mrad	25 mrad	51 mrad	80 mrad
Separation Angle	25 mrad	51 mrad	101 mrad	160 mrad
Acoustic Velocity	6.31E+3 m/sec →		6.31E+3 m/sec →	
Maximum RF Power	1 W	1 W	1 W	630 mW
Input Impedance	50 ohms	50 ohms	50 ohms	50 ohms
V.S.W.R.	2:1	2:1	2:1	2:1
Optical Polarization	Linear, horizontal (parallel to sound direction)			
Case Type	# 200	# 200	# 200	# 200

## IR Modulators (1.15 to 1.60 μm)

### Models IPM-80-13, IPM-200-26, & IPM-400-100

	<b>IPM-80-13</b>	<b>IPM-200-26</b>	<b>IPM-400-100</b>
Data Performed @	1.15 μm	1.15 μm	1.15 μm
Optical Power Density	1 Watts/mm <sup>2</sup>	1 Watts/mm <sup>2</sup>	1 Watts/mm <sup>2</sup>
Center Frequency	80 MHz	200 MHz	400 MHz
Active Aperture	1.0 mm	0.3 mm	0.075 mm
Beam Diameter Inside Crystal	0.25 mm	0.13 mm	0.031 mm
Rise Time	42 ns	21 ns	5 ns
Digital Modulation Bandwidth	13 MHz	26 MHz	100 MHz
Analog Video Bandwidth	8.2 MHz	16.5 MHz	68.5 MHz
Optical Transmission	> 90 %	> 90 %	> 90 %
Diffraction Efficiency	70 %	60 %	50 %
Wave Front Distortion	λ/10	λ/10	λ/10
Bragg Angle (mrad)	9 mrad	22 mrad	44 mrad
Separation Angle	18 mrad	44 mrad	88 mrad
Acoustic Velocity	5.1 E+3 m/sec	5.1 E+3 m/sec	5.1 E+3 m/sec
Maximum RF Power	1 W	1 W	1 W
Input Impedance	50 ohms	50 ohms	50 ohms
V.S.W.R.	2:1	2:1	2:1
Optical Polarization	Linear	Linear	Linear
Case Type	# 40	# 200	# 200



## High Speed UV-VIS-IR Modulator (0.38 to 1.6 μm)

### Models TEM-200-50, TEM-400-100, & TEM-800-200

	<b>TEM-200-50</b>	<b>TEM-400-100</b>	<b>TEM-800-200</b>
Data Performed @	633 nm	633 nm	633 nm
Optical Power Density	5 Watts/mm <sup>2</sup>	5 Watts/mm <sup>2</sup>	5 Watts/mm <sup>2</sup>
Center Frequency	200 MHz	400 MHz	800 MHz
Active Aperture	0.3 mm	0.075 mm	0.05 mm
Beam Diameter Inside Crystal	0.05 mm	0.027 mm	0.013 mm
Rise Time	10 ns	5.5 ns	3 ns
Digital Modulation Bandwidth	50 MHz	100 MHz	200 MHz
Analog Video Bandwidth	34 MHz	63 MHz	128 MHz
Optical Transmission	> 95 %	> 95 %	> 95 %
Diffraction Efficiency	70 %	50 %	35 %
Wave Front Distortion	λ/10	λ/10	λ/10
Bragg Angle (mrad)	20	30	60
Separation Angle	39	60	120
Acoustic Velocity	4.2 E+3 m/sec	4.2 E+3 m/sec	4.2 E+3 m/sec
Maximum RF Power	1 W	1 W	1 W
V.S.W.R.	2:1	2:1	2:1
Input Impedance	50 ohms	50 ohms	50 ohms
Optical Polarization	Linear, perpendicular to sound direction →		
Case Type	# 200	# 200	# 200

## Optical Assembly for Acousto-Optic Modulators

The optical module for Acousto-Optic modulators consists of a focusing lens, A-O device positioners, and a recollimating lens. The incoming light is focused inside the A-O device and the beam diameter at the focal point is a function of the required rise time and modulation bandwidth. The type of lenses used depends upon the A-O device and its speed requirements, which will define the module size and lens positions. Typical dimensions are shown in the above figure.

Model #: **AMOA-X-Y-L**

where

X = the diameter of the input beam in mm  
 Y = the beam diameter at the focal point inside the crystal in mm  
 L = the laser wavelength



## Modulator Drivers

**(For Models: AMM-27-2, AMM-80-4, AMM-100-8, AMM-100-13)**

	<b>FFA-27-B1(2)</b>	<b>FFA-80-B1(4)</b>	<b>FFA-100-B1(8)</b>	<b>FFA-100-B1(13)</b>
Carrier Frequency (MHz)	27	80	100	100
Frequency Control	Quartz Crystal Referenced Phase Locked Loop →			
Frequency Accuracy	0.015%	0.015%	0.015%	0.015%
Harmonic Content	≤ -15 dBc	≤ -15 dBc	≤ -15 dBc	≤ -15 dBc
Stability	0.0015% Minimum After 15 Minute Warm-up →			
Output Power	1 W	1 W	1 W	0.5 - 1 W
Modulation	B1 Analog Amplitude →			
Maximum Analog Modulation Bandwidth (MHz)	DC-2	DC-4	DC-8	DC-13
Modulation Input	0-5 V; High Z Input	50 Ū; 0-1 V	50 Ū; 0-1 V	50 Ū; 0-1 V
Operating Power	117 VAC ± 25%, 50-60 Hz; 55 W max. →			
Enclosure	The unit will be packed in a nominal 6.75 inch wide by 2.6 inch high by 8.3 inch deep instrument case. The rear panel heat sink increases depth to 10.5 inch max. Size is exclusive of connector. A detachable AC line cord is provided.			
Environmental	Nominal laboratory conditions: max temperature +35° C; the unit is not sealed against moisture of condensing humidity.			
<b><i>TTL Modulation (B2) also available with the following specifications:</i></b>				
	<b>FFA-27-B2(2)</b>	<b>FFA-80-B2(4)</b>	<b>FFA-100-B2(8)</b>	<b>FFA-100-B2(13)</b>
Bandwidth	DC-2 MHz	DC-4 MHz	DC-8 MHz	DC-13 MHz
Rise Time	< 125 nsec	< 50 nsec	< 35 nsec	< 30 nsec
Modulation Input	TTL Compatible; 0-5 V, 330 Ū Input Impedance →			

**(For Models: FQM-80-2, FQM-80-20, FQM-200-40)**

	<b>FFA-80-B1(3)</b>	<b>FFA-80-B1(18)</b>	<b>FFA-200-B1(40)</b>
Carrier Frequency (MHz)	80	80	200
Frequency Control	Quartz Osc.	Quartz Osc.	P.L.L.
Frequency Accuracy	0.015%	0.015%	0.015%
Harmonic Content	≤ - 15 dBc	≤ - 15 dBc	≤ -15 dBc
Stability	0.0015% Minimum After 15 Minute Warm-up →		
Output Power	5 W	3.5 W	3.5 W
Modulation	B1 Analog Amplitude →		
Maximum Analog Modulation Bandwidth (MHz)	DC-3	DC-18	DC-40
Modulation Input	50 Ū; 0-1 V	50 Ū; 0-1 V	50 Ū; 0-1 V
Operating Power	117 VAC ± 25%, 50-60 Hz; 55 W max. →		
Enclosure	The unit will be packed in a nominal 6.75 inch wide by 2.6 inch high by 8.3 inch deep instrument case. The rear panel heat sink increases depth to 10.5 inch max. Size is exclusive of connectors. A detachable AC line cord is provided.		
Environmental	Nominal laboratory conditions: max temperature +35° C; the unit is not sealed against moisture of condensing humidity.		
<b><i>TTL Modulation (B2) also available with the following specifications:</i></b>			
	<b>FFA-80-B2(2)</b>	<b>FFA-80-B2(20)</b>	<b>FFA-200-B2(40)</b>
Bandwidth	DC-2 MHz	DC-20 MHz	DC-40 MHz
Rise Time	< 125 nsec	< 18 nsec	< 9 nsec
Modulation Input	TTL Compatible; 0-5 V, 330 Ū Input Impedance →		



## Modulator Drivers

**(For Models: GEM-40-1, GEM-40-4, GEM-60-10)**

	<b>FFA-40-B1(1)</b>	<b>FFA-40-B1(5)</b>	<b>FFA-60-B1(10)</b>
Carrier Frequency (MHz)	40	40	60
Frequency Control	Quartz Crystal Referenced Phase Locked Loop →		
Frequency Accuracy	0.015%	0.015%	0.015%
Harmonic Content	≤ -15 dBc	≤ -15 dBc	≤ -15 dBc
Stability	0.0015% Minimum After 15 Minute Warm-up →		
Output Power	20-30 W	25 W	8 W
Modulation	B1 Analog Amplitude →		
Maximum Analog Modulation Bandwidth (MHz)	DC-1	DC-5	DC-10
Modulation Input	0-5 V; High Z Input	50 Ω; 0-1 V	50 Ω; 0-1 V
Operating Power	117 VAC ± 25%, 50-60 Hz; 55 W max. →		
Enclosure	The unit will be packed in a forced air cooled 7.5 inch wide by 3.5 inch high by 8.75 inch deep instrument case. The internal components are fan forced air cooled. Size is exclusive of connectors. A detachable AC line cord is provided.		
Environmental	Nominal laboratory conditions: max temperature +35° C; the unit is not sealed against moisture of condensing humidity.		
<b><i>TTL Modulation (B2) also available with the following specifications:</i></b>			
	<b>FFA-40-B2(1)</b>	<b>FFA-40-B2(5)</b>	<b>FFA-60-B2(10)</b>
Bandwidth	DC-1 MHz	DC-5 MHz	DC-10 MHz
Rise Time	< 250 nsec	< 50 nsec	< 35 nsec
Modulation Input	TTL Compatible; 0-5 V, 330 Ω Input Impedance →		

**(For Models: GPM-200-50, GPM-400-100, GPM-800-200, GPM-1600-400, IPM-200-26, IPM-400-100, TEM-200-50, TEM-400-100, TEM-800-200)**

	<b>FFA-200-B1(50)</b>	<b>FFA-400-B1(100)</b>	<b>FFA-800-B1(200)</b>	<b>FFA-1600-B1(400)</b>
Carrier Frequency (MHz)	200	400	800	1600
Frequency Control	Quartz Crystal Referenced Phase Locked Loop →			
Frequency Accuracy	0.015%	0.015%	0.015%	0.015%
Harmonic Content	≤ -15 dBc	≤ -15 dBc	≤ -15 dBc	≤ -15 dBc
Stability	0.0015% Minimum After 15 Minute Warm-up →			
Output Power	1 W	1 W	1 W	630 mW
Modulation	B1 Analog Amplitude →			
Maximum Analog Modulation Bandwidth (MHz)	DC-50	DC-100	DC-200	DC-400
Modulation Input	50 Ω; 0-1 V	50 Ω; 0-1 V	50 Ω; 0-1 V	50 Ω; 0-1 V
Operating Power	117 VAC ± 25%, 50-60Hz; 55W max. →			
Enclosure	The unit will be packed in a nominal 6.75 inch wide by 2.6 inch high by 8.3 inch deep instrument case. The rear panel heat sink increases depth to 10.5 inch max. Size is exclusive of connector. A detachable AC line cord is provided.			
Environmental	Nominal laboratory conditions: max temperature +35°C; the unit is not sealed against moisture of condensing humidity.			
<b><i>Digital Modulation (B2) also available with the following specifications:</i></b>				
	<b>FFA-200-B2(50)</b>	<b>FFA-400-B2(100)</b>	<b>FFA-800-B2(200)</b>	<b>FFA-1600-B2(400)</b>
Bandwidth	DC-50 MHz	DC-100 MHz	DC-200 MHz	DC-400 MHz
Rise Time	< 7 nsec	< 3.5 nsec	< 1.8 nsec	< 0.9 nsec
Modulation Input	0-1 V, 50 Ω Input Impedance →, TTL Compatible; 0-5 V, 330 Ω Input Impedance →			

**Brimrose Corporation of America**  
 19 Loveton Circle  
 Baltimore, MD 21152-9201 USA  
 Phone: +1 410 472-7070  
 Fax: +1 410 472-7960  
 E-Mail: [offices@brimrose.com](mailto:offices@brimrose.com)  
 Web: <http://www.brimrose.com>

**BRIMROSE**



## Modulator Drivers

**(For Models: TEM-85-2, TEM-85-10, IPM-80-13, TEM-110-25)**

	<b>FFA-85-B1</b>	<b>FFA-85-B1(10)</b>	<b>FFA-80-B1(13)</b>	<b>FFA-110-B1(25)</b>
Carrier Frequency (MHz)	85	85	80	110
Frequency Control	Quartz Crystal Referenced Phase Locked Loop →			
Frequency Accuracy	0.015%	0.015%	0.015%	0.015%
Harmonic Content	≤ -15 dBc	≤ -15 dBc	≤ -15 dBc	≤ -15 dBc
Stability	0.0015% Minimum After 15 Minute Warm-up →			
Output Power	1 W	1 W	1 W	0.5-1 W
Modulation	B1 Analog Amplitude →			
Maximum Analog Modulation Bandwidth (MHz)	DC-2	DC-10	DC-13	DC-25
Modulation Input	0-5 V; High Z	50 Ω; 0-1V	50 Ω; 0-1 V	50 Ω; 0-1 V
Operating Power	117 VAC ± 25%, 50-60 Hz; 55 W max. →			
Enclosure	The unit will be packed in a nominal 6.75 inch wide by 2.6 inch high by 8.3 inch deep instrument case. The rear panel heat sink increases depth to 10.5 inch max. Size is exclusive of connector. A detachable AC line cord is provided.			
Environmental	Nominal laboratory conditions: max temperature +35°C; the unit is not sealed against moisture of condensing humidity.			
<i>TTL Modulation (B2) also available with the following specifications:</i>				
	<b>FFA-85-B2(2)</b>	<b>FFA-85-B2(10)</b>	<b>FFA-80-B2(13)</b>	<b>FFA-110-B2(25)</b>
Bandwidth	DC-2 MHz	DC-10 MHz	DC-13 MHz	DC-25 MHz
Rise Time	< 125 nsec	< 35 nsec	< 30 nsec	< 14 nsec
Modulation Input	TTL Compatible; 0-5 V, 330 Ω Input Impedance →			

**Case # 35**

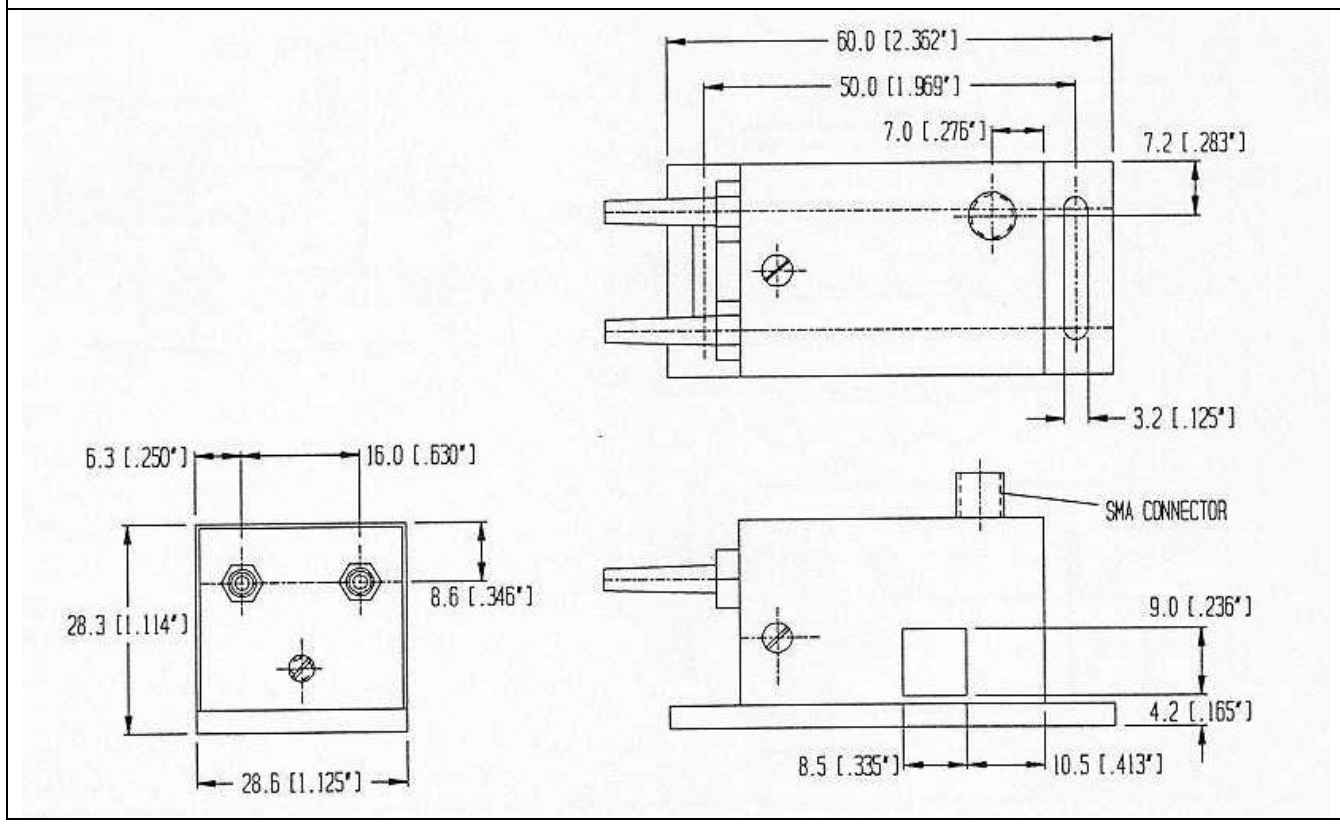

**Brimrose Corporation of America**  
19 Loveton Circle  
Baltimore, MD 21152-9201 USA  
Phone: +1 410 472-7070  
Fax: +1 410 472-7960  
E-Mail: [offices@brimrose.com](mailto:offices@brimrose.com)  
Web: <http://www.brimrose.com>

**BRIMROSE**



Case # 60

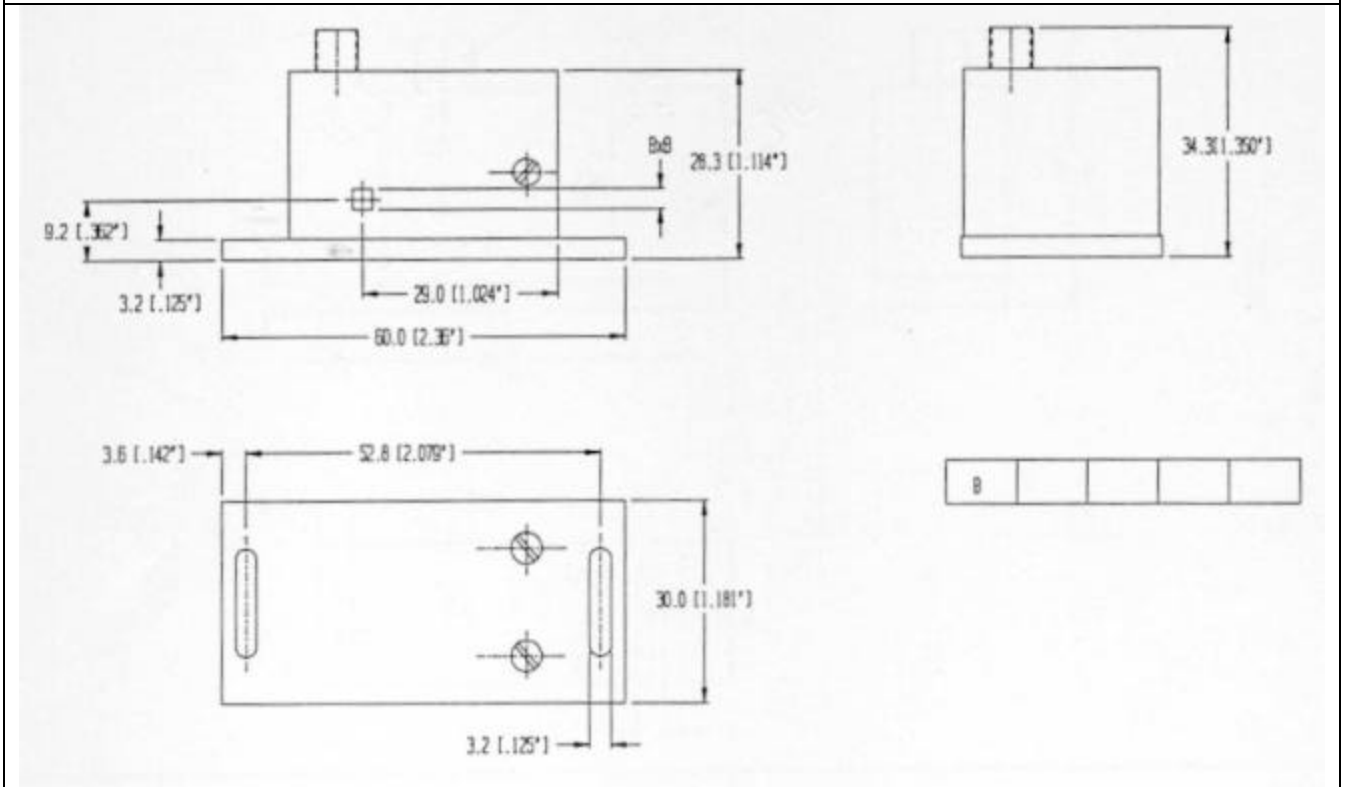

**Brimrose Corporation of America**  
19 Loveton Circle  
Baltimore, MD 21152-9201 USA  
Phone: +1 410 472-7070  
Fax: +1 410 472-7960  
E-Mail: [offices@brimrose.com](mailto:offices@brimrose.com)  
Web: <http://www.brimrose.com>

**BRIMROSE**



**Case # 90**

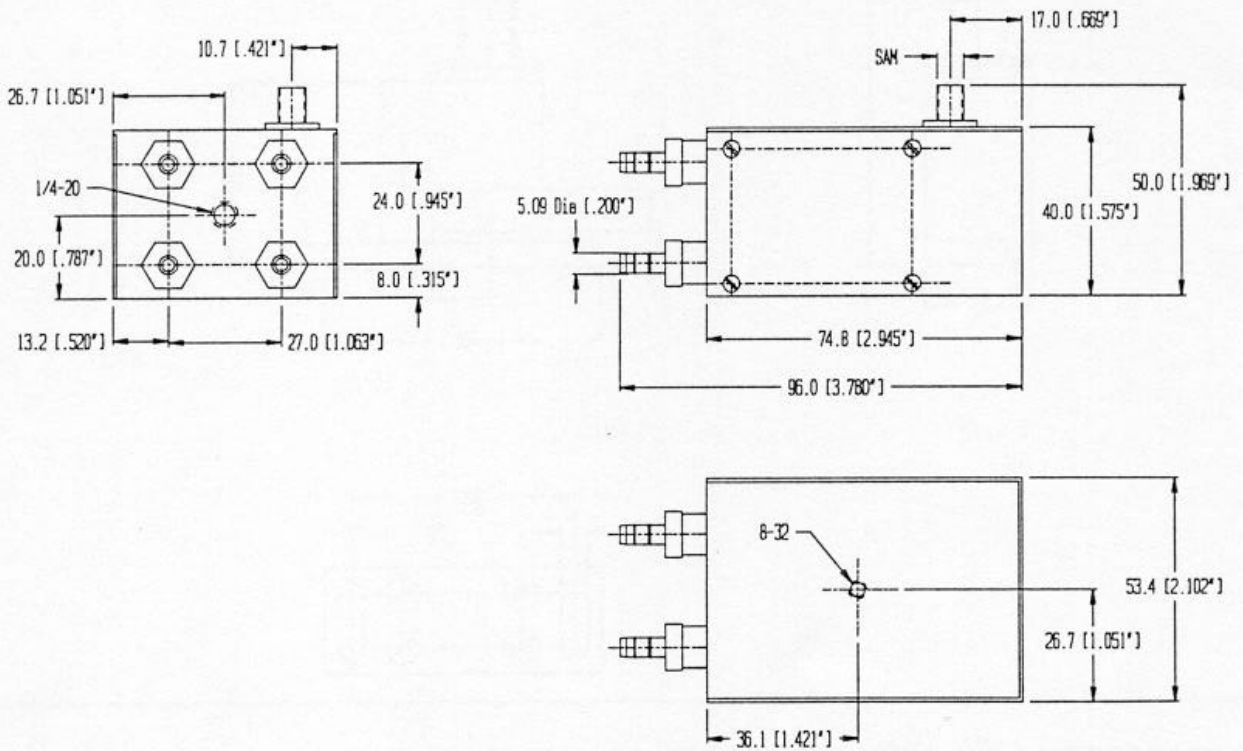



Case # 130

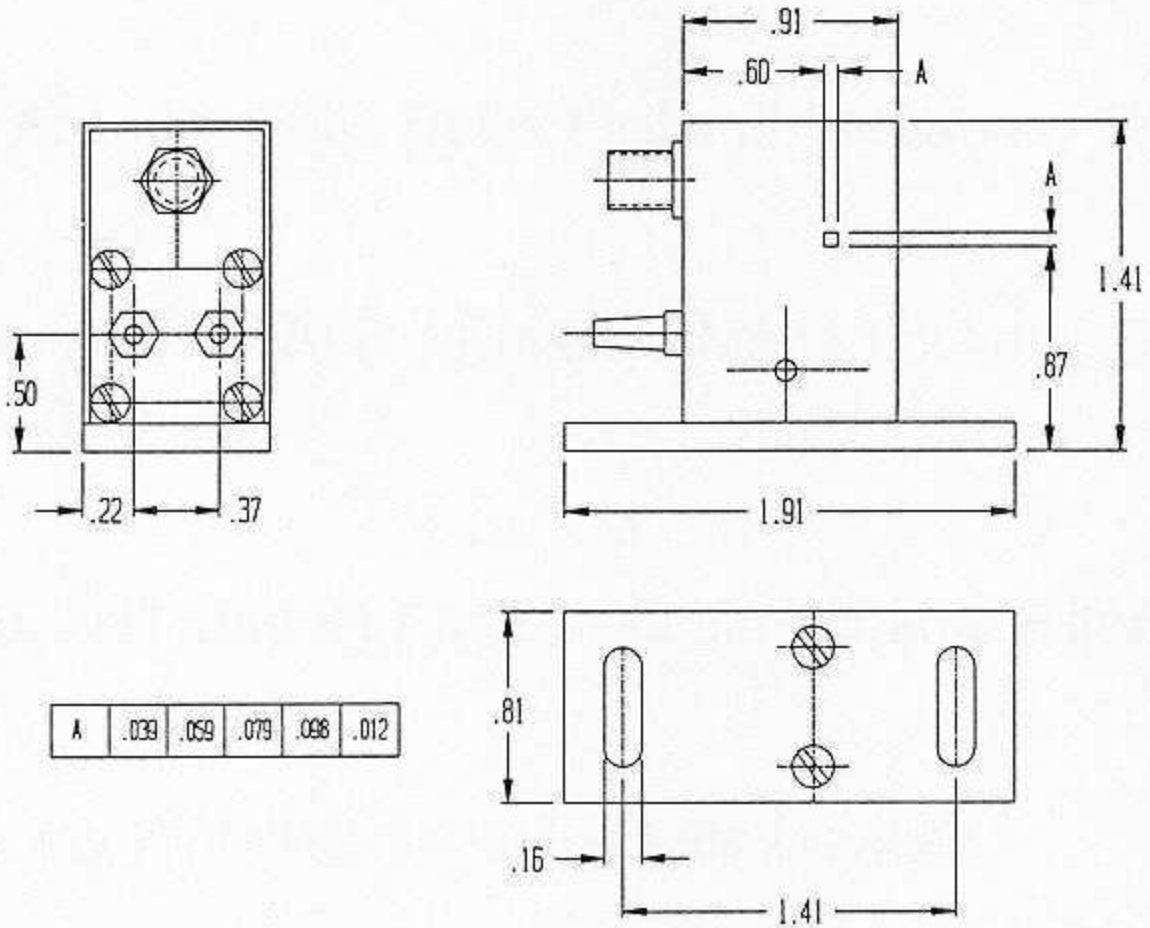



**Case # 200**

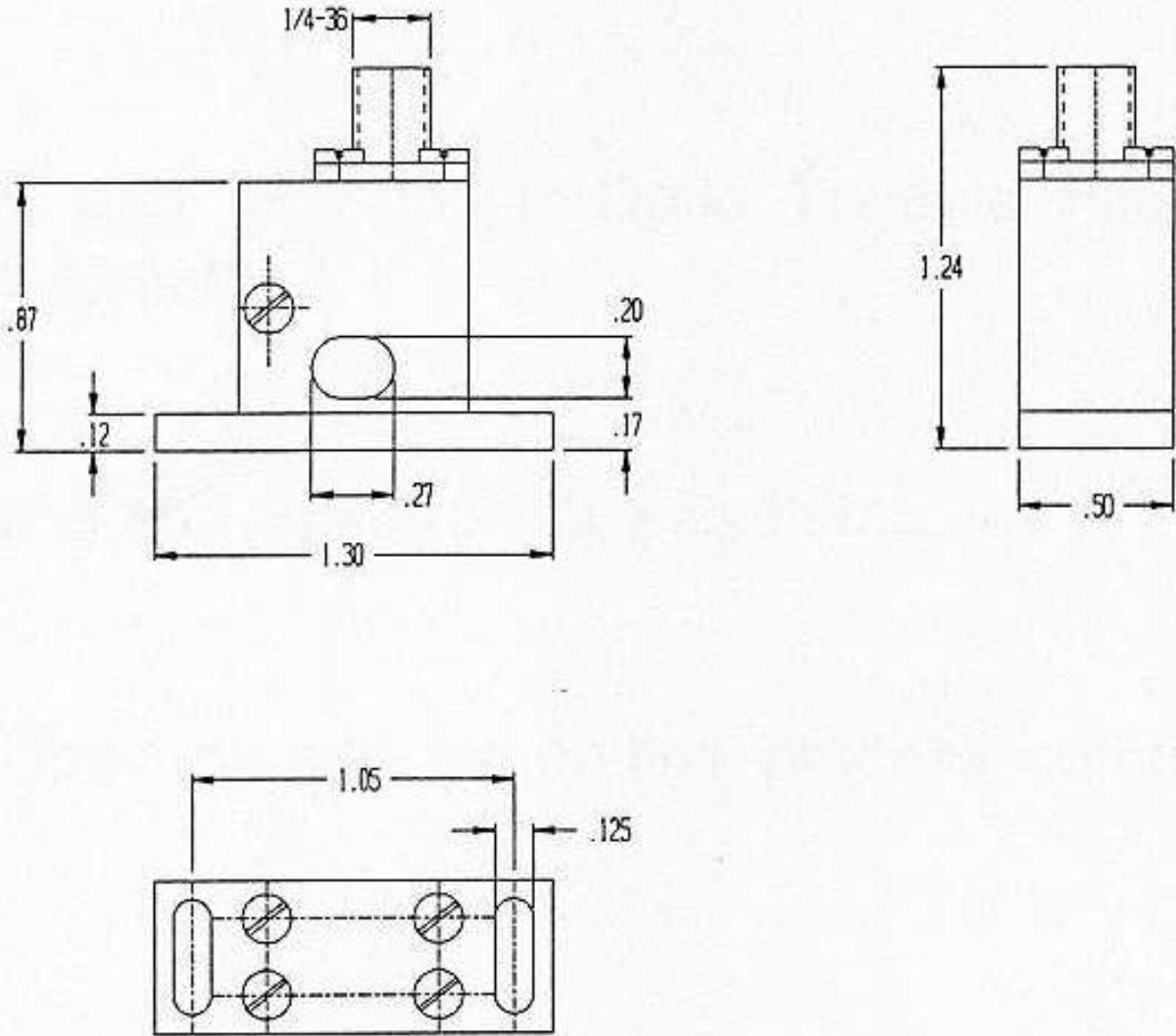



## References

1. J.I. Soos and R. G. Rosemeier, "A New High Efficiency InP Acousto-optic Device for IR wavelengths," SPIE's Orlando '90 Symposium in Orlando, FL (April 1990).
2. J.I. Soos and R. G. Rosemeier, "A New High Efficiency  $\text{Ge}_{33}\text{A}_{12}\text{Se}_{55}$  Acousto-Optic Device for Near IR Wavelengths," SPIE's OE/LASE Symposium in Los Angeles, CA (January 1990).
3. J.I. Soos and R.G. Rosemeier, "High Frequency Traveling Wave and Standing Wave Acousto Optic Modulators," SPIE's 33<sup>rd</sup> Annual Technical Symposium in San Diego (August 1989).
4. J.I. Soos, D.C. Leepa, and R.G. Rosemeier, "Optical Multiplications with Single Element 2-D Acousto-Optic Laser Beam Deflector," SPIE's 1989 OE/Laser Symposium (January 1989).
5. J.I. Soos and R.G. Rosemeier, "High Frequency GaAs Bulk Acousto-Optic Devices for Modulators and Frequency Shifters at 1.3 $\mu\text{m}$  and 1.5 $\mu\text{m}$  in Fiber Optics," at SPIE's OE/Fiber Laser '88 Conference in Boston, MA (September 1988).
6. J.I. Soos T.P. McFerrin, R.L. Scheerer, and N.L. Baldwin, "2 1/2GHz Bandwidth  $\text{LiNbO}_3$  Shear Bragg Cells," at SPIE's Technical Symposium on Optics, Electro-Optics, and Sensors in Orlando, FL (April 1988).
7. J.I. Soos and R.G. Rosemeier, "Novel In-Line Acousto-Optic Fiber-Optic Switch," at SPIE's O-E/Laser '88 Conference in Los Angeles, CA (January 1988).
8. J.I. Soos, R.G. Rosemeier and J. Rosenbaum, "GHz Bandwidth Shear Wave GaP Acousto-Optic Beam Steering," at SPIE's 31<sup>st</sup> Annual Technical Symposium in San Diego, CA (August, 1987).
9. I.C. Chang, "Acousto-Optic Devices and Applications," IEEE Proceedings, Sonics and Ultrasonics, pp. 1-22, Jan.1976.
10. N. Uchida and N. Niizeki, "Acousto-Optic Deflection Materials and Techniques," IEEE Proceedings, pp.1073-1092, Aug, 1973.
11. L. Dickson, "Optical Considerations for an Acousto-Optic Deflector," Applied Optics, pp. 2196-2202, Oct.1972.
12. J. Randolph and J. Morrison, "Modulation Transfer Characteristics of an Acousto-Optic Deflector," Applied Optics, pp. 1383-1385, June 1971.
13. E.I. Gordon, "A Review of Acousto-Optical Deflection and Modulation Devices", Proc. IEEE, pp.1391-1401, Oct. 1966.